

3-1 Installing the Drive

Chapter 3 INSTALLING THE DRIVE

IMPORTANT: Read Chapter 10: "Certification for the Drive" before installing this unit.

Mechanical Installation

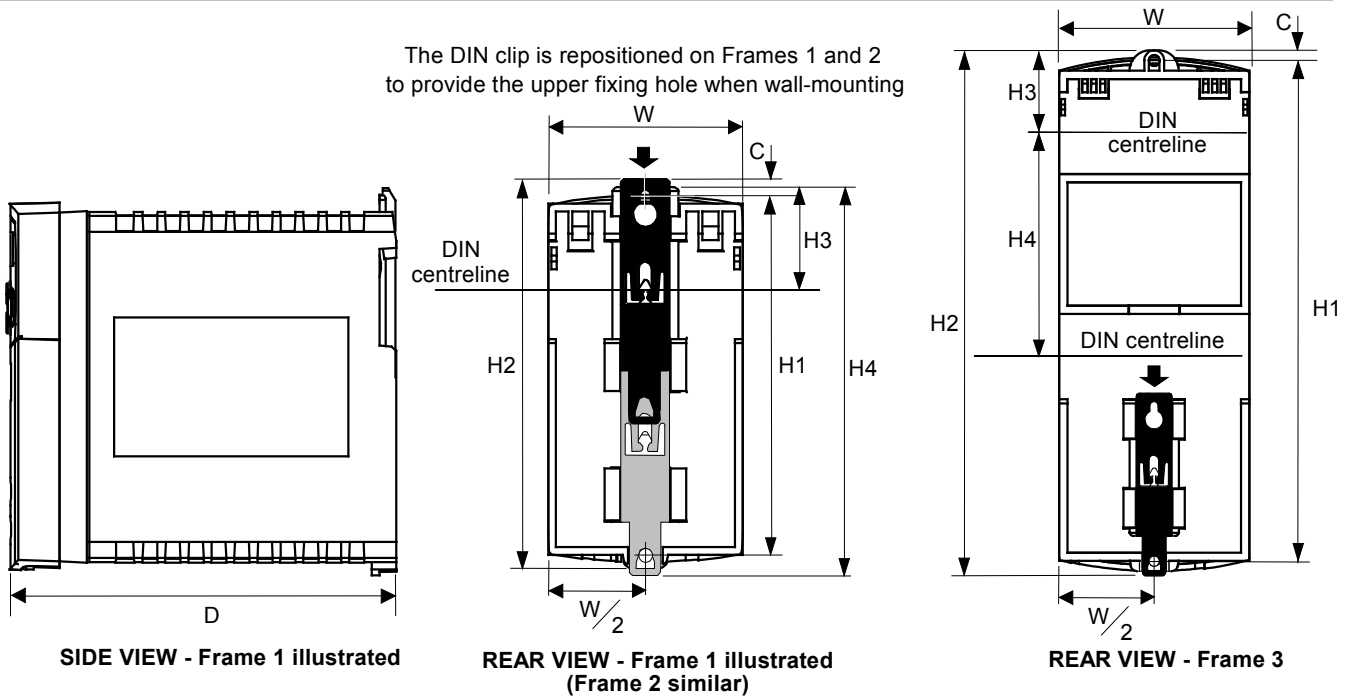

	Fixing	Torque	Weight	H1 Fixing Centres	H2	H3	H4	C	W	D
Frame 1	M4	1.5Nm	0.85kg (2 lbs)	132 (5.2")	143 (5.6")	35 (1.4")	139 (5.5")	6 (0.2")	73 (2.9")	142 (5.6")
Frame 2	M5	3.0Nm	1.4kg (3 lbs)	188 (7.4")	201 (7.9")	35 (1.4")	194 (7.7")	6.5 (0.24")	73 (2.9")	173 (6.8")
Frame 3	M5	3.0Nm	2.7kg (6 lbs)	242 (9.5")	260 (10.2")	38 (1.5")	112 (4.4")	5 (0.2")	96 (3.8")	200 (7.9")

Dimensions are in millimetres (inches)

Mounting the Drive

To maintain compliance with European Electrical Safety Standard VDE0160(1994)/EN50178 (1998) the unit must be mounted inside a control cubicle that requires a tool for opening. The cubicle should provide 15dB attenuation to radiated emissions between 30-100MHz.

Mount the drive vertically on a solid, flat, non-flammable, vertical surface. It can be panel-mounted, or rail-mounted on a rail complying with EN50022 (35mm DIN).

DIN Mounting

To DIN mount the unit, hang the unit on the top DIN rail and push the unit onto the bottom DIN rail until it snaps in to position. Secure with a lower screw fixing. To release the unit, use a flat bladed screwdriver as shown.

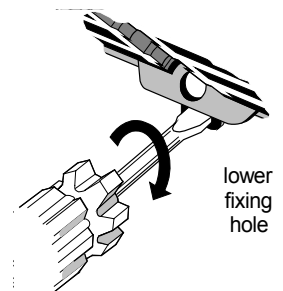

Ventilation

Maintain a minimum air clearance for ventilation of 100mm (4 inches) above and below the unit. When mounting two or more 650V units together, these clearances are additive. Ensure that the mounting surface is normally cool. Be aware that adjacent equipment may generate heat and also have clearance requirements. Provided the minimum clearance for ventilation is maintained, 650V drives may be mounted side-by-side.

Chapter 3

INSTALLING THE DRIVE

IMPORTANT: Read Chapter 9: "Certification for the Drive" before installing this unit.

Mechanical Installation

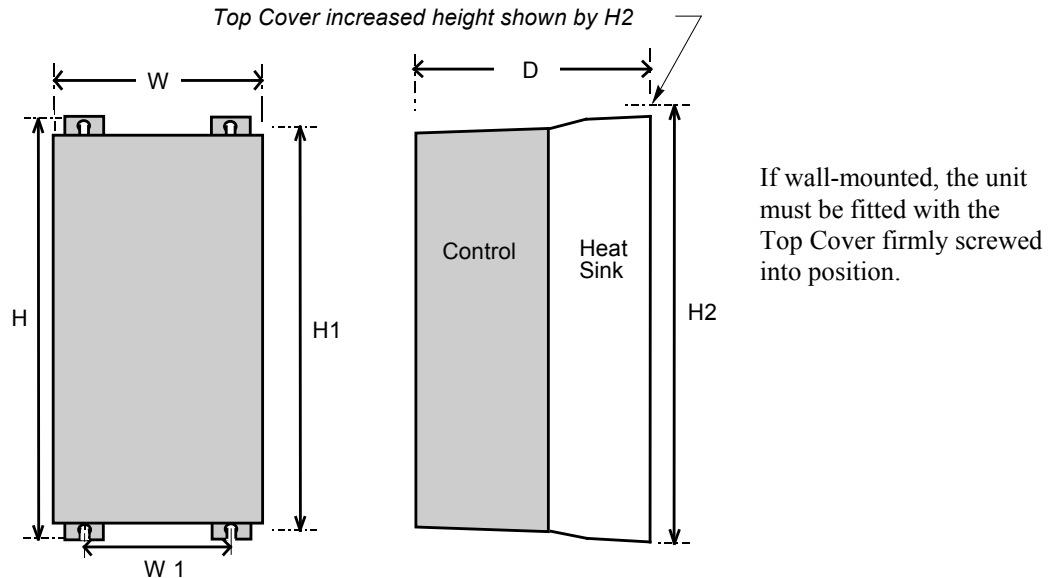

Approximate Frame C shown for illustration purposes

Figure Chapter 3 -1 Mechanical Dimensions for 650V Drives

Models	Max. Weight kg/lbs	H	H1	H2	W	W1	D	Fixings
Frame C	9.3/20.5	348.0 (13.70)	335.0 (13.19)	365.0 (14.37)	201.0 (7.91)	150 (5.90)	208.0 (8.19)	Slot 7mm wide Use M5 or M6 fixings.
Frame D	17.4/38.2	453.0 (17.8)	440.0 (17.3)	471.0 (18.5)	252.0 (9.92)	150 (5.90)	245.0 (9.65)	Slot 7mm wide Use M5 or M6 fixings.
Frame E	32.5/72	668.6 (26.3)	630.0 (24.8)	676.0 (26.6)	257.0 (10.1)	150.0 (5.9)	312 (12.3)	Use M6 fixings
Frame F	41/90.4	720.0 (28.3)	700.0 (27.6)	Not applicable	257.0 (10.1)	150.0 (5.9)	355.0 (14.0)	Use M6 fixings
All dimensions are in millimetres (inches)								

Note: For details of a through-panel mounting option for Frames D & E refer to pages 3-5 and 3-7 respectively.

Mounting the Drive

The unit must be mounted vertically on a solid, flat, vertical surface. It can be wall-mounted, or mounted inside a suitable cubicle, depending upon the required level of EMC compliance - refer to Chapter 9: "Technical Specifications".

Ventilation

The drive gives off heat in normal operation and must therefore be mounted to allow the free flow of air through the ventilation slots and heatsink. Maintain minimum clearances for ventilation as given in the tables below to ensure adequate cooling of the drive, and that heat generated by other adjacent equipment is not transmitted to the drive. Be aware that other equipment may have its own clearance requirements. When mounting two or more 650V units together, these clearances are additive. Ensure that the mounting surface is normally cool.